



CW25-TIM

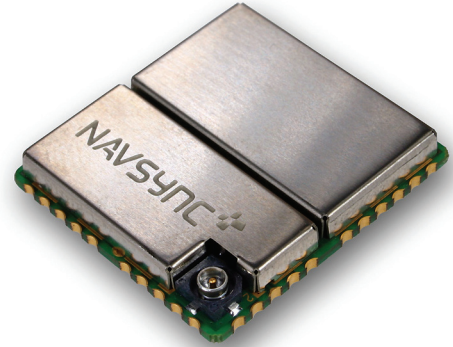



TABLE OF CONTENTS

1	INTRODUCTION	5
2	SPECIFICATION	6-7
2.1	Performance	6
2.2	Recommended Ratings	7
2.3	Absolute Maximum Ratings	7
2.4	Block Diagram	7
3	PHYSICAL CHARACTERISTICS	8-9
3.1	Physical Interface Details	8
3.2	CW25-TIM Dimensions	9
3.3	Solder Pad Size and Placement	9
4	SIGNAL DESCRIPTION	10-14
4.1	Power Signals	10
4.2	RF Signals	11
4.3	Emulation/Test Signals	11
4.4	Control Signals	12
4.5	I/O Signals	13
5	SPECIAL FEATURES	15
5.1	User Commands	15
5.2	Self-Survey	15
5.3	CW25-TIM Embedded Identification	15
6	TAPE AND REEL SPECIFICATIONS	16
7	SOLDER PROFILE	16
8	DEMO KIT INFORMATION	16
9	APPLICATION HINTS	17
9.1	Power Supply	17
9.2	RF Connection	17
9.3	Grounding	18
9.4	Battery Backup	18
9.5	Over Voltage & Reverse Polarity Protection	19
9.6	LEDs	19
9.7	Reset Generation	19
9.8	Boot Options	19

Figure and Table Contents

List of Figures

Figure 1 CW25-TIM Block Diagram-----	7
Figure 2 CW25-TIM Form and Size -----	8
Figure 3 CW25-TIM Dimensions -----	9
Figure 4 Solder Pad Size and Placement-----	10
Figure 5 RF Tracking Example-----	17
Figure 6 Grounding the CW25-TIM with a ground plane-----	18
Figure 7 Typical VBATT Supplies-----	19

List of Tables

Table 1 Revision History -----	2
Table 2 Additional Documentation List -----	3
Table 3 CW25-TIM Specification-----	6
Table 4 Absolute Maximum Ratings -----	7
Table 5 Absolute Maximum Ratings -----	7
Table 6 CW25-TIM Signal List-----	8
Table 7 RF Track & Gap Widths -----	17

Revision History of Version 1.0

Revision	Date	Released By	Note
01	08/08/05	Rob Rae	New version reflecting interfaces performance
02	07/03/07	Katie Foote	
03	08/20/07	Katie Foote	Testing & evaluating update
04	04/23/08	Katie Foote	Pin revisions & miscellaneous revisions
05	09/24/08	Katie Foote	Temp & dBW to dBm
06	01/22/09	Dave Jahr	Remove max velocity & altitude spec
07	03/26/09	Donal Geoghegan	Demo board Kit information
08	04/13/10	Dave Jahr	Update to 1PPS (timing) accuracy specification

Table 1 Revision History

Other Documentation

The following additional documentation may be of use in understanding this document.

Document	By	Note
CW25 User Manual	NavSync	
CW25 Dev Kit User Manual	NavSync	

Table 2 Additional Documentation List

1 INTRODUCTION

The CW25-TIM is a small GPS OEM module that has been optimized for precision timing applications. The CW25-TIM leverages 12,288 correlators in the BB251C baseband processor for low signal acquisition and tracking, eliminating the need for an outdoor antenna in many applications. Aside from low signal tracking, the CW25-TIM's algorithms also support quick Time To First Fix (TTFF) in cold start conditions or when ephemeris and almanac data is available. To optimize timing performance, CW25-TIM fixes its position after initially acquiring satellites and performing a survey. When the position is fixed, even in severely degraded signal conditions, the CW25-TIM can continue to provide a time solution with only one available satellite.

With a size of just over an inch square (25 x 27 mm) and provided as a tape and reel component, the CW25-TIM is specifically designed to be integrated with communications devices such as GSM, CDMA, UMTS modems or any other communications medium. The CW25-TIM is optimized for the output of time/ frequency information. Another aid to integration is the ability to store users' software code in the CW25-TIM, reducing the need for external memory and processors.

Key Features of the CW25-TIM include:

- 25 ns accuracy to UTC
- Enables indoor use
 - 155 dBm acquisition with network assist
 - 156 dBm tracking
 - 143 dBm acquisition stand alone
- Rapid time to fix
 - <2 second outdoors
 - <5 second indoors (-148dBm)
- Stand-alone CW25-TIM module
 - No GPS knowledge required for hardware integration
- 25 mm x 27 mm x 4.2 mm

This document, the CW25-TIM Data Sheet, provides information on the hardware and software elements of the CW25-TIM.

Key information includes:

- System Block Diagram
- Maximum Ratings
- Physical Characteristics
 - CW25-TIM Dimensions, Castellation Information
 - Solder Pad and Placement Information
- Signal Descriptions
- Special Features
- Application Information
 - Power Supply Modes
 - RF Connections
 - Grounding
 - Battery Back-up
 - Over Voltage and Reverse Polarity
 - LED's

The specifications in the following sections refer to the standard software builds of the CW25-TIM. The performance and specification of the CW25-TIM can be modified with the use of customized software builds.

2 SPECIFICATION ¹

2.1 Performance

Physical	Module Dimensions	25mm (D) x 27mm (W) x 4.2mm (H)
	Supply Voltages	3V3 (Digital I/O), 3V3 (RF), 1V8 (Core option), 3V (Standby Battery)
	Operating Temp	-30°C to +80°C
	Storage Temp	-40°C to +85°C ²
	Humidity	5% to 95% non-condensing
	Max Acceleration / Jerk	4g / 1gs ⁻¹ (sustained for less than 5 seconds)
Sensitivity	Acquisition with Network Assist	-155dBm
	Tracking	-156dBm
	Acquisition Stand Alone	-143dBm
Acquisition Time	Hot Start with Network Assist	Outdoor: <2s Indoor (-148dBm): <5s
	Stand Alone (Outdoor)	Cold: <45s
		Warm: <38s
		Hot: <5s
	Reacquisition: <0.5s (90% confidence)	
Accuracy	Position: Outdoor / Indoor	<5m rms / <50m rms
	Velocity	<0.05ms ⁻¹
	Latency	<200ms
	Raw Measurement Accuracy	Pseudorange <0.3m rms, Carrier phase <5mm rms
	Tracking	Code and carrier coherent
Power	1 Fix per Second	0.6W typically
	Coma Mode Current (RF3V3+DIG 3V3)	10mA
	Standby Current (VBATT)	1.5µA
Interfaces	Serial	3 UART ports, CMOS levels
	Multi-function I/O	1PPS and Frequency Output available on GPIO [0]
		Event Counter/Timer Input
		Up to 4 x GPIO (multi-function)
		2 x LED Status Drive
		I ² C, External Clock (on special build)
	Protocols	Network assist, NMEA 0183, proprietary ASCII and binary message formats
	1pps Timing Output	10nS rms accuracy, <5nS resolution User selectable pulse width
	Event Input	30nS rms accuracy, <10nS resolution
	Frequency Output (GPIO [0])	10 Hz to 30 MHz (CW25-TIM)
Receiver Type	12 parallel channel x 32 taps up to 32 point FFT. Channels, taps and FFT can be switched off to minimize power or simulate simpler designs.	
General	Processor	ARM 966E-S on a 0.18µ process at up to 120 MHz.

Note: 1. The features listed above may require specific software builds and may not all be available in the initial release.

2. Please contact factory for other temperature options.

Table 3 CW25-TIM Specification

2 SPECIFICATION continued

2.2 Recommended Ratings

Symbol	Parameter	Min	Max	Units
RF_3V3	RF Supply Voltage	+3.0	+3.6	Volts
DIG_3V3	Digital Supply Voltage	+3.0	+3.6	Volts
DIG_1V8	Digital Supply Voltage	+1.65	+1.95	Volts
VBATT	Battery Backup Voltage	+2.7	+3.5	Volts
ANT_SUPPLY	Antenna Supply Voltage	+3.0	+12	Volts

Table 4 Recommended Maximum Ratings

2.3 Absolute Maximum Ratings

Symbol	Parameter	Min	Max	Units
RF_3V3	RF Supply Voltage	-0.3	+6.5	Volts
DIG_1V8	Digital Supply Voltage	-0.3	+2.0	Volts
DIG_3V3	Digital Supply Voltage	-0.3	+3.7	Volts
VBATT	Battery Backup Voltage	-0.5	+7.0	Volts
ANT_SUPPLY	Antenna Supply Voltage	-15	+15	Volts
DIG_SIG_IN	Any Digital Input Signal	-0.3	+5.5	Volts
RF_IN	RF Input	-15	+15	Volts
TSTORE	Storage temperature	-40	+85	°C
IOUT	Digital Signal Output Current	-6	+6	mA

Table 5 Absolute Maximum Ratings

2.4 Block Diagram

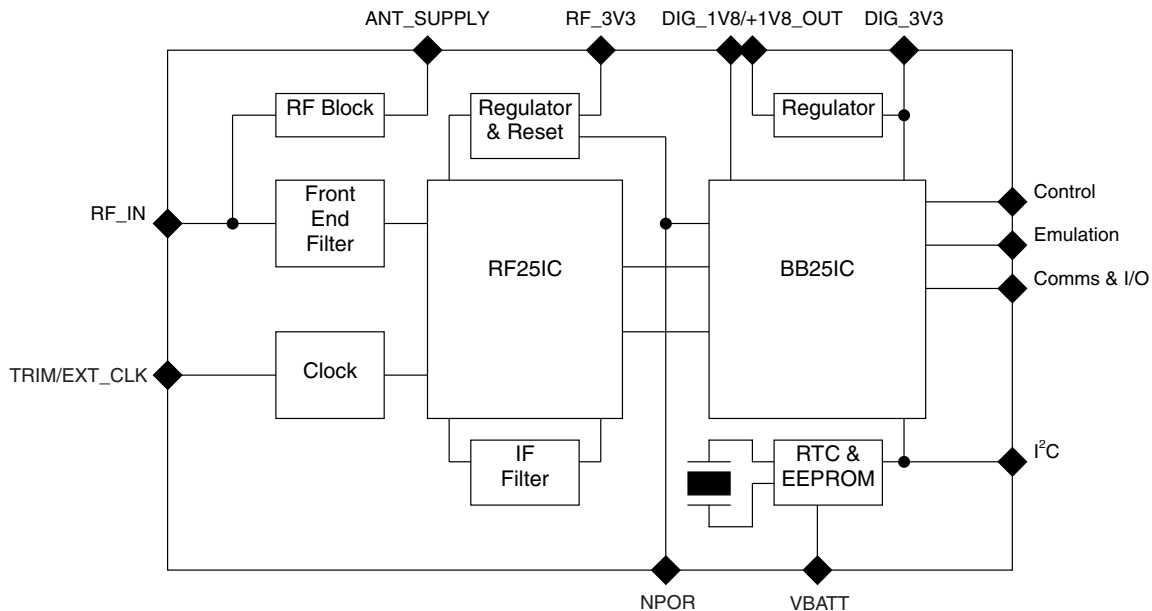

Figure 1 CW25-TIM Block Diagram

3 PHYSICAL CHARACTERISTICS

The CW25-TIM is a multi-chip module (MCM) built on an FR4 fiberglass PCB. All digital and power connections to the CW25-TIM are via castellations on the 25 x 27 mm PCB. The RF connection is via castellations or an RF connector. The general arrangement of the CW25-TIM is shown in the diagram below. Dimensions are in mm (inches/1000).

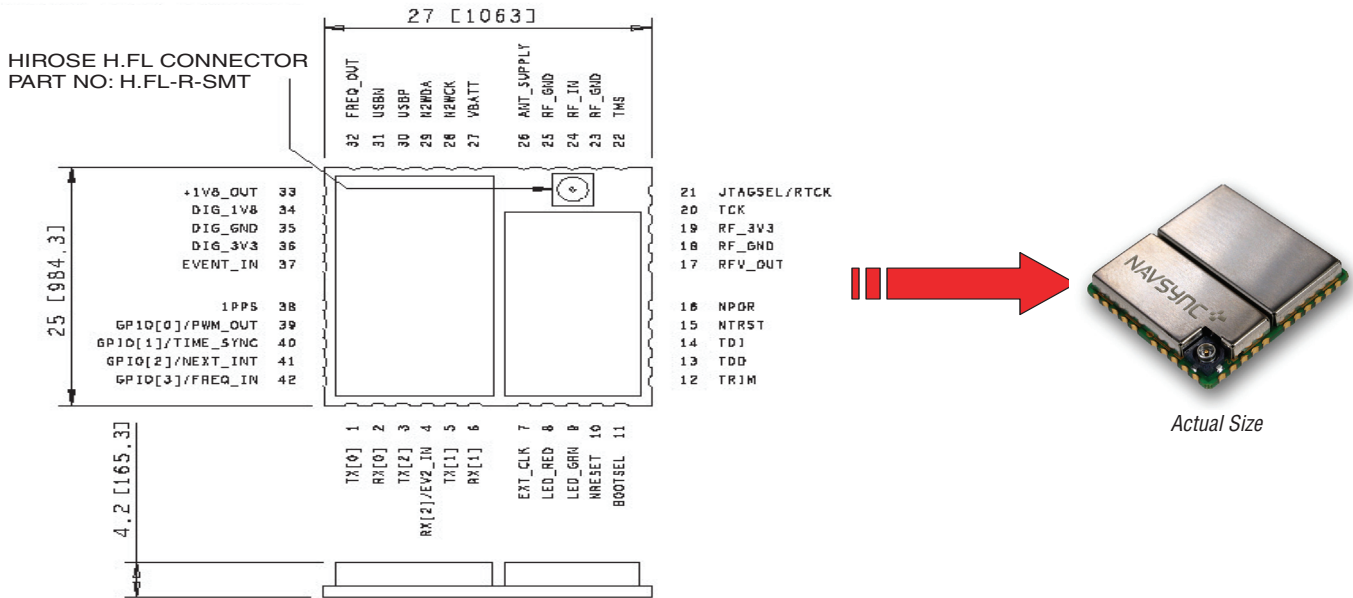

Figure 2 CW25-TIM Form and Size

3.1 Physical Interface Details

The interface to the CW25-TIM is via 1mm castellations on a 2mm pitch. There are 42 connections in all. There is also an RF connector for connecting to the GPS antenna. The details of the interface connections are given below.

Pin	Function	Pin	Function	Pin	Function
1	TX[0]	15	NTRST	29	N2WDA
2	RX[0]	16	NPOR	30	USBP
3	TX[2]	17	RFV_OUT	31	USBN
4	RX[2]/EV2_IN	18	RF_GND	32	FREQ_OUT
5	TX[1]	19	RF_3V3	33	+1V8_OUT
6	RX[1]	20	TCK	34	DIG_1V8
7	EXT_CLK	21	JTAGSEL/RTCK	35	DIG_GND
8	LED_RED	22	TMS	36	DIG_3V3
9	LED_GRN	23	RF_GND	37	EVENT_IN
10	NRESET	24	RF_IN	38	1PPS
11	BOOTSEL	25	RF_GND	39	GPIO[0]/PWM_OUT ³
12	TRIM	26	ANT_SUPPLY	40	GPIO[1]/TIME_SYNC
13	TDO	27	VBATT	41	GPIO[2]/NEXT_INT
14	TDI	28	N2WCK	42	GPIO[3]/FREQ_IN

Note: 3. Frequency output is available on pin 32 (FREQ_OUT) with custom software only.

Table 6 CW25-TIM Signal List

3 PHYSICAL CHARACTERISTICS continued

3.2 CW25-TIM Dimensions

The figure below provides the dimensions of the positioning of the CW25-TIM castellations. Dimensions are in mm (inches/1000).

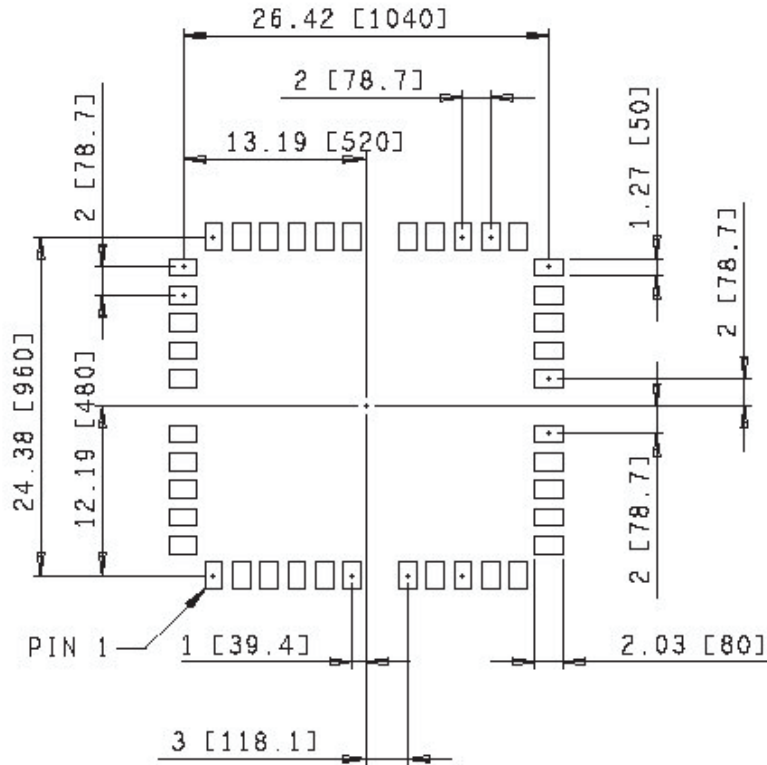

Figure 3 CW25-TIM Dimensions

3.3 Solder Pad Size and Placement

It is recommended that the footprint of the solder pad under each castellation be 2mm x 1mm, centered on the nominal center point of the radius of the castellation. The castellations are gold plated and lead free. Note that if the RF_IN connector is being used, there should not be a pad or solder resist under the RF_IN castellation. If the RF_IN castellation is to be used, the pad should be shortened by 0.5mm underneath the CW25-TIM and standard RF design practices must be observed. The diagram below shows the placement of the pads under the castellations.



Figure 4 Solder Pad Size and Placement

4 SIGNAL DESCRIPTION

The signals on the CW25-TIM are described in the table below.

4.1 Power Signals

RF_3V3	Type: Power	Direction: Input	Pin: 19
The RF Supply Input. This $3.3V \pm 10\%$ input supplies the 2.9V LDO regulator in the RF section of the CW25-TIM. It is important that this supply is well filtered with no more than 50mV peak to peak noise with respect to RF_GND.			
RF_GND	Type: Power	Direction: Input/Output	Pins: 18, 23, 25
The RF Input Ground. This is the return path for the RF_3V3 supply and the ground for the antenna feed. The RF_GND must be tied to the DIG_GND externally to the CW25-TIM.			
RFV_OUT	Type: Power	Direction: Output	Pin: 17
The output from the LDO regulator that is powered by the RF_3V3 signal. This supplies the power to the RF subsystem of the CW25-TIM. This may also be used to power external RF components but care must be taken not to inject noise onto this signal. No more than an additional 30mA may be taken from this signal by external circuitry.			
ANT_SUPPLY	Type: Power	Direction: Input	Pin: 26
The Antenna Supply Voltage. This may be used to supply power to the RF_IN signal, for use by an active antenna. The maximum voltage should not exceed $\pm 15V$ and the current should be limited to 50mA.			
DIG_3V3	Type: Power	Direction: Input	Pin: 36
The Digital Supply Input. This $3.3V \pm 10\%$ input supplies the I/O ring of the BB25IC chip and the LDO regulator in the digital section of the CW25-TIM. It is important that this supply is well filtered with no more than 50mV peak to peak noise with respect to DIG_GND.			
DIG_1V8	Type: Power	Direction: Input	Pin: 34
The $1.8V \pm 5\%$ digital core supply for the BB25IC. This is normally connected directly to the +1V8_OUT signal. However, if an external $1.8V \pm 5\%$ is available, a lower overall system power consumption may be achieved by using an external supply.			
+1V8_OUT	Type: Power	Direction: Output	Pin: 33
The 1.8V output from the LDO regulator that is powered by the DIG_3V3 signal. Normally, this is connected to the DIG_1V8 signal. This may also be used to power external logic but care must be taken not to inject noise onto this signal. No more than an additional 50mA may be taken from this signal by external logic.			
DIG_GND	Type: Power	Direction: Input/Output	Pin: 35
The Digital Ground. This is the return path for the DIG_3V3 supply and the ground reference for all the digital I/O. The DIG_GND must be tied to the RF_GND externally to the CW25-TIM.			

4 SIGNAL DESCRIPTION continued

4.1 Power Signals cont'd

VBATT	Type: Power	Direction: Input/Output	Pin: 27
<p>The Battery Backup Supply. The CW25-TIM has an on board Real Time Clock (RTC). This is powered from the VBATT signal. A supply of typically 3v (greater than 2.5V and less than DIG_3V3) should be applied to this signal. This signal can be left floating if not required. The input has a blocking diode and so rechargeable batteries will need an external charging circuit. Typically, a 1K resistor in series with this signal and the external battery will provide an easy method of measuring the current consumption from VBATT during test.</p>			

4.2 RF Signals

RF_IN	Type: RF	Direction: Input	Pin: 24
<p>The RF Input Signal. This attaches to the GPS antenna. Standard RF design rules must be used when tracking to this signal. This signal has an RF blocked connection to the ANT_SUPPLY signal. This is the same signal presented on the RF connector on the CW25-TIM. Only one antenna connection should be made. If the RF connector is to be used, then there should be no connection, even an unconnected pad, to this castellation.</p>			

TRIM	Type: RF	Direction: Input	Pin: 12
<p>This signal trims the output frequency of the VCTCXO. This signal is normally left open. When floating, this signal is biased to the control voltage of the VCTCXO. Any noise injected into this signal will severely compromise the performance of the CW25-TIM. This signal should only be used in conjunction with specific application notes.</p>			

EXT_CLK	Type: RF	Direction: Input	Pin: 7
<p>This input is the external clock input. This signal is to be used only in special builds of the CW25 that are not fitted with an internal VCTCXO. For the normal build, containing the VCTCXO, do not connect this input. The external clock is a 9 MHz to 26 MHz clipped sinewave input with an amplitude between 1V and 3V peak to peak. The return path for this signal is RF_GND.</p>			

4.3 Emulation/Test Signals

TDI	Type: Test	Direction: Input	Pin: 14
<p>The Test Data In Signal. This is the standard JTAG test data input. The signal return path is DIG_GND.</p>			

TDO	Type: Test	Direction: Output	Pin: 13
<p>The Test Data Out Signal. This is the standard JTAG test data output. The signal return path is DIG_GND.</p>			

TCK	Type: Test	Direction: Input	Pin: 20
<p>The Test Clock Signal. This is the standard JTAG test clock input. The signal return path is DIG_GND.</p>			

4 SIGNAL DESCRIPTION continued

4.3 Power Signals cont'd

TMS	Type: Test	Direction: Input	Pin: 22
The Test Mode Select Signal. This is the standard JTAG test mode input. The signal return path is DIG_GND.			
JTAGSEL/RTCK	Type: Test	Direction: Input/Output	Pin: 21
This signal selects the function of the JTAG interface. However, the JTAG interface is not user accessible. Pull it to VCC (DIG_3V3) through a 1K resistor for normal operation.			
NTRST	Type: Test	Direction: Input	Pin: 15
The Test Reset Signal. This is the active low JTAG test reset signal. The signal return path is DIG_GND.			

4.4 Control Signals

NPOR	Type: Control	Direction: Input/Output	Pin: 16
The Power On Reset Signal. This active low, open collector signal is the master reset for the CW25-TIM. The CW25-TIM can be held in reset by asserting this signal. The signal can be used to reset external circuitry, but care must be taken to ensure no DC current is drawn from this signal as the internal pull-up resistor value is 100K.			
NRESET	Type: Control	Direction: Input/Output	Pin: 10
The System Reset Signal. This active low, open collector signal is generated by the BB25IC chip in response to the assertion of the NPOR. It may also be driven to reset the ARM9 processor in the BB25IC without completely re-initializing the chip.			
BOOTSEL	Type: Control	Direction: Input	Pin: 11
The Boot Select Signal. The BB25IC has four boot up modes, but only two are supported by the CW25-TIM. This signal is sampled when the NPOR is de-asserted. If the BOOTSEL signal is high or left floating, then the CW25-TIM boots from its on-chip FLASH memory. If the BOOTSEL signal is pulled low, the CW25-TIM boots from its on-chip ROM.			

4 SIGNAL DESCRIPTION continued

4.5 I/O Signals

TX[0]	Type: I/O	Direction: Output	Pin: 1
The Transmit Signal for UART 0. This is a standard UART output signal. The signal return path is DIG_GND.			
TX[1]	Type: I/O	Direction: Output	Pin: 5
The Transmit Signal for UART 1. This is a standard UART output signal. The signal return path is DIG_GND.			
TX[2]	Type: I/O	Direction: Output	Pin: 3
The Transmit Signal for UART 2. This is a standard UART output signal. The signal return path is DIG_GND.			
RX[0]	Type: I/O	Direction: Input	Pin: 2
The Receive Signal for UART 0. This is a standard UART input signal. The signal return path is DIG_GND.			
RX[1]	Type: I/O	Direction: Input	Pin: 6
The Receive Signal for UART 1. This is a standard UART input signal. The signal return path is DIG_GND.			
RX[2]/EV2_IN	Type: I/O	Direction: Input	Pin: 4
This is a Dual Mode Signal. Normally, this is the receive signal for UART 2, a standard UART receive signal. Under software control, it can also be used as general purpose I/O or to detect events. It can be used to detect the timing of the leading edge of the start bit of the incoming data stream. The signal return path is DIG_GND.			
FREQ_OUT	Type: I/O	Direction: Input/Output	Pin: 32
Optional Frequency Output Signal. This is NOT the same signal as pin 39. This signal is turned off by default. This is a complex signal which under software can provide any of either an NCO generated output frequency, a PWM signal, a GPS aligned EPOCH pulse or general purpose I/O signal. The signal return path is DIG_GND.			
1PPS	Type: I/O	Direction: Input/Output	Pin: 38
The 1 Pulse Per Second Signal. This is normally a 1 pulse aligned with GPS time, but can under software control also provide general purpose I/O or an additional event input. The pulse width of the 1PPS is software selectable with a default of 100µs. The signal return path is DIG_GND.			
EVENT_IN	Type: I/O	Direction: Input/Output	Pin: 37
The Event Input Signal. This is normally an event timer or counter. Events are timed against GPS time. Under software control, this input can be used as an external 48 MHz input for the USB interface or this input can also be used for general purpose I/O. The signal return path is DIG_GND.			
N2WCK	Type: I/O	Direction: Input/Output	Pin: 28
The NavSync 2 Wire Clock Signal. This is the open collector I2C compatible clock signal for the 2 wire serial interface. The signal return path is DIG_GND.			

4 SIGNAL DESCRIPTION continued

4.5 I/O Signals cont'd

N2WDA	Type: I/O	Direction: Input/Output	Pin: 29
The NavSync 2 Wire Data Signal. This is the open collector I2C compatible data signal for the 2 wire serial interface. The signal return path is DIG_GND.			
USBP ⁴	Type: I/O	Direction: Input/Output	Pin: 30
The positive USB Signal. The signal return path is DIG_GND.			
USBN ⁴	Type: I/O	Direction: Input/Output	Pin: 31
The negative USB Signal. The signal return path is DIG_GND.			
LED_RED	Type: I/O	Direction: Output	Pin: 8
This is a dual function signal. Normally this signal is used to drive a red LED. Standard software builds use this signal to indicate GPS status, where a long red flash indicates an invalid fix and Short red flashes for satellites tracked, but not used in solution. In special software builds, this signal can be used as GPIO. This signal has a 3.3V CMOS drive. A series limiting resistor is required to limit output current to $\pm 5\text{mA}$. The signal return path is DIG_GND.			
LED_GRN	Type: I/O	Direction: Output	Pin: 9
This is a dual function signal. Normally this signal is used to drive a green LED. Standard software builds use this signal to indicate GPS status, where a long green flash indicates an valid 2D/3D fix and short green flashes for number of satellites used in solution. In special software builds, this signal can be used as GPIO. This signal has a 3.3V CMOS drive. A series limiting resistor is required to limit output current to $\pm 5\text{mA}$. The signal return path is DIG_GND.			
GPIO[0]/PWM	Type: I/O	Direction: Input/Output	Pin: 39
Normally the GPIO[0]/PWM output provides a frequency output that defaults to 10 MHz, and is user configurable from 10 Hz to 30 MHz signal. The output is enabled on power-up and is steered by the GPS solution. Custom software versions can also configure this pin for general I/O, PWM or EPOCH output. The signal return path is DIG_GND.			
GPIO[1]/TIME_SYNC	Type: I/O	Direction: Input/Output	Pin: 40
The GPIO[1]/TIME_SYNC pin provides a synchronization pulse generated by the on-board RTC. Custom software versions can also configure this pin for general purpose I/O, or an additional PPS output. The signal return path is DIG_GND.			
GPIO[2]/NEXT_INT	Type: I/O	Direction: Input/Output	Pin: 41
The GPIO[2]/NEXT_INT output provides an active high status indicator for the Frequency Output available on pin 39 (GPIO[0]/PWM). Custom software versions can also configure this pin for general purpose I/O. The signal return path is DIG_GND.			
GPIO[3]/FREQ_IN	Type: I/O	Direction: Input/Output	Pin: 42
The GPIO[3]/FREQ_IN output provides an active high status 3D fix indicator. This indicator can also be used to determine the validity of the pin 38 (1PPS) output. The signal return path is DIG_GND.			

Note: 4. USB is not supported in the current software build.

5 SPECIAL FEATURES

While most of the features on the CW25-TIM are just a subset of the capabilities of the CW25 and so are described in the CW25 Data Sheet and the CW25 User Manual, there are some additional features specific to the CW25-TIM that require explanation.

5.1 User Commands

The CW25-TIM can accept a number of specific user commands for setting receiver parameters such as UART baud rate and NMEA message subset, output frequency, etc. Many of these parameters are stored in Non-Volatile Memory (NVM) so that the settings are retained when the receiver loses power. The available commands are defined in detail in the CW25 User Manual.

5.2 Self Survey

To optimize timing performance, the CW25-TIM performs a 10-minute survey each time the receiver is powered up and after obtaining a GPS fix. When the survey is complete, the receiver automatically enters fixed timing mode. For applications with specific timing performance requirements, it may be necessary to allow the survey to complete before using the 1PPS and frequency outputs. The status of the survey can be determined by querying the receiver dynamics setting as described in the CW25 User Manual.

5.3 CW25-TIM Embedded Identification

The hardware version number is hard coded onto the CW25-TIM; firmware also contains a version number allowing for easy identification of the hardware and software version in embedded applications.

6 TAPE AND REEL SPECIFICATIONS

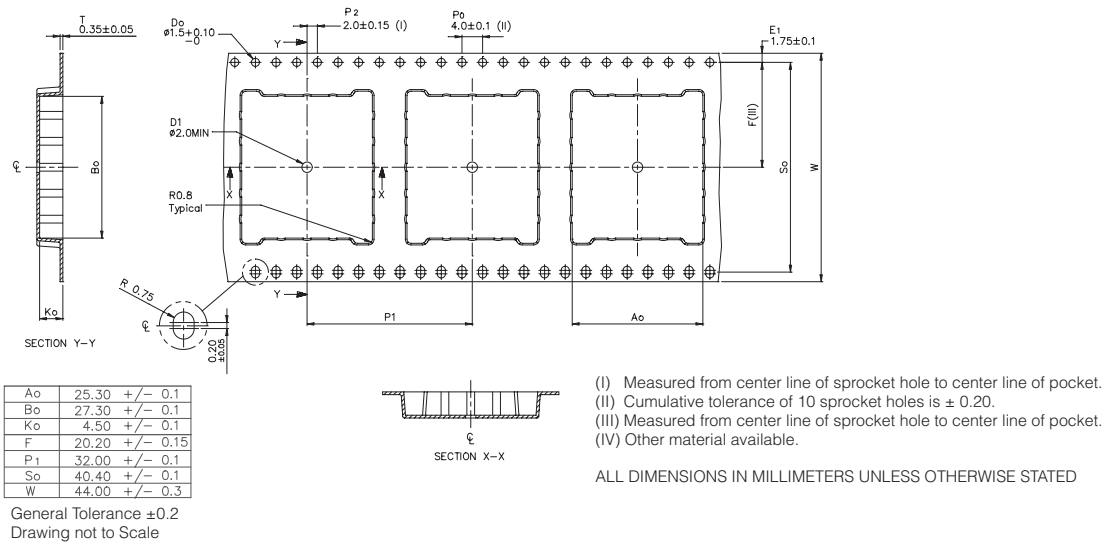

Figure 5 Tape and Reel

7 SOLDER PROFILE

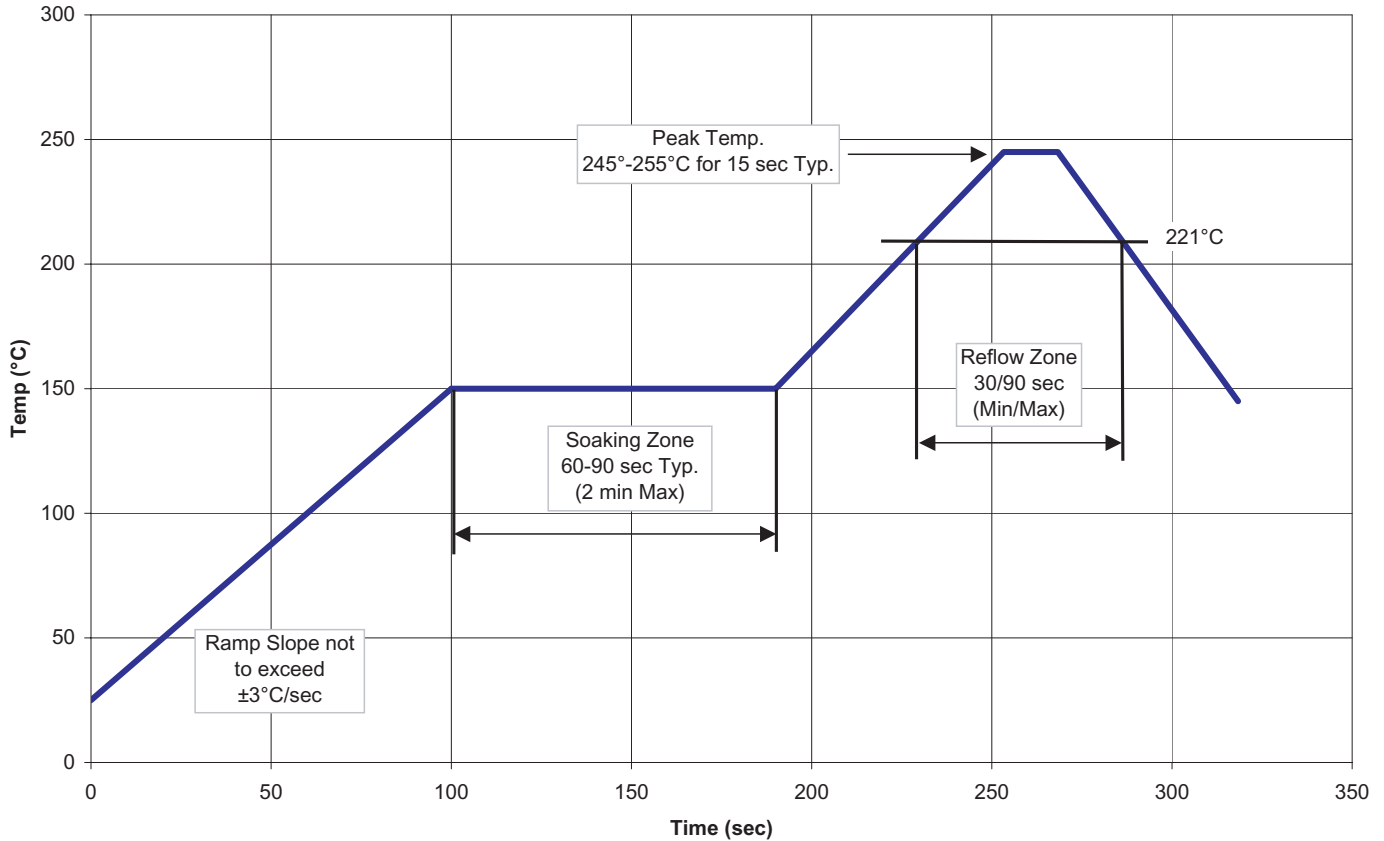

Figure 6 Solder Profile

8 DEMO KIT INFORMATION

A CW25 demo board is available for evaluation of the CW25 receiver. A full kit contains the demo board with mounted CW25-TIM or CW25-NAV, RS232 serial cable, power supply adaptor (region specific) with a 2.1 mm DC plug and a 3m TNC magnetic patch antenna.

To reduce costs, the CW25 demo board can be purchased separately with a pick-and-choose option for above accessories.

See CW25 Demo User Manual for more detailed information on this unit.

Please contact NavSync for pricing information on the full kit or individual items.

9 APPLICATION HINTS

The following are a list of application hints that may help in implementing system based on the CW25-TIM.

9.1 Power Supply

The power supply requirements of the CW25-TIM can all be provided from a single 3.3V supply. To simplify system integration on-board regulators provide the correct voltage levels for the RF and oscillator (2.9V or 3.0V) and low voltage digital core (1.8V). In power sensitive applications it is recommended that the DIG_1V8 supply is provided from a high efficiency external 1.8V source e.g. switch mode power supply, rather than the on-board linear regulator.

If the source impedance of the power supply to the CW25-TIM is high due to long tracks, filtering or other causes, local decoupling of the supply signals may be necessary. Make sure the maximum supply ripple at the pins of the CW25-TIM is 50mV peak to peak.

9.2 RF Connection

The RF connection to the CW25-TIM can be done in two ways. The preferred method is to use standard microstrip design techniques to track from the antenna element to the RF_IN castellation. This also allows the systems integrator the option of designing in external connectors suitable for the application. The user can easily fit an externally mounted MCX, SMA or similar connector, provided it is placed adjacent to the RF_IN castellation. If the tracking guidelines given below are followed, the impedance match will be acceptable. The diagram below shows how this could be achieved. In this diagram, the center via of the RF connector is presumed to be plated through with a minimal pad top and bottom. The PCB material is assumed to be 1.6mm thick FR4 with a dielectric constant of 4.3. Two situations are considered; one with no ground plane and one with a ground plane on the bottom of the board, underneath the RF connector. In both cases there is no inner layer tracking under the RF connector.

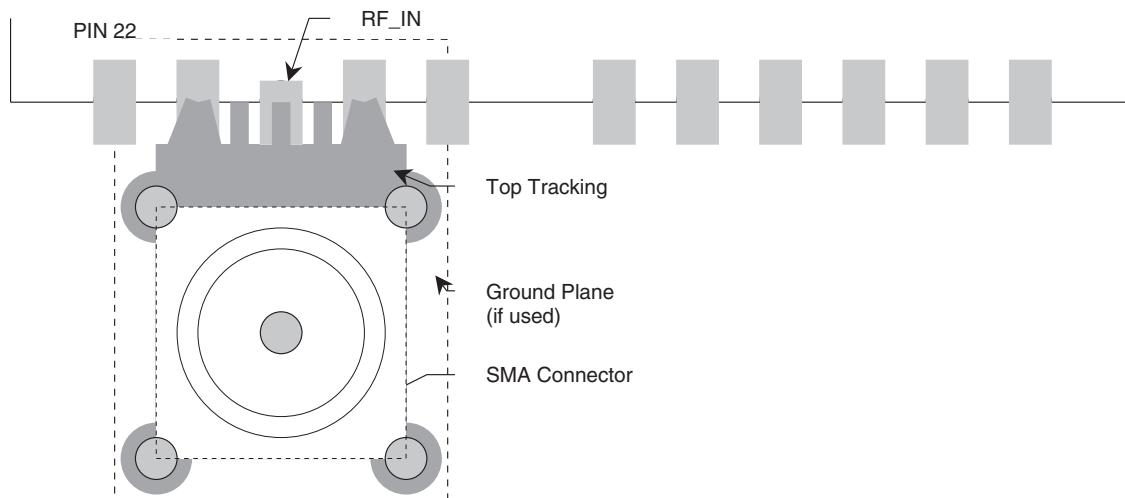

Figure 7 RF Tracking Example

The widths of the RF_IN track and the associated gaps are given in the table below.

Scenario	Track Width (1/1000 Inch)	Gap Width (1/1000 Inch)
Without ground plane	37	6
	56	8
With ground plane	32	6
	43	8

Table 7 RF Track & Gap Widths

Alternatively, the user can attach the antenna to the Hirose H.FL-R-SMT using a flying lead fitted with a suitable plug.

9 APPLICATION HINTS continued

9.3 Grounding

In connecting the CW25-TIM into a host system, good grounding practices should be observed. Specifically, ground currents from the rest of the system hosting the CW25-TIM should not pass through the ground connections to the CW25-TIM. This is most easily ensured by using a single point attachment for the ground. There must also be a good connection between the RF_GND and the DIG_GND signals. While there is not a specific need to put a ground plane under the CW25-TIM, high energy signals should not be tracked under the CW25-TIM. However, it is recommended that a ground plane be used under the CW25-TIM. In this case, the following would be an example of the pattern that may be used

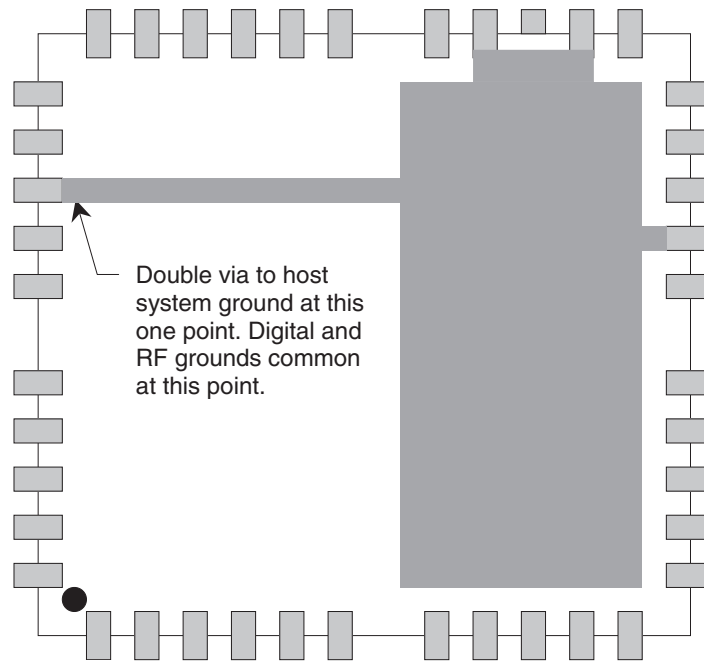

Figure 8 Grounding the CW25-TIM with a Ground Plane

9.4 Battery Backup

The CW25-TIM has an on-board real time clock (RTC). This is used to store date and time information while the CW25-TIM is powered down. Having a valid date and time speeds the Time To First Fix (TTFF), allowing the CW25-TIM to meet its quoted TTFF specification. The CW25-TIM relies on an external power source to power the RTC (VBATT) when the DIG_3V3 is not present. If the user application does not require the warm or hot fix performance, or the required information is provided by network assistance, there is no need to provide the VBATT signal. The VBATT signal must be greater than 2.6V and less than DIG_3V3 + 0.6V. Typically, a 3V lithium primary cell or a high capacity "supercap" will be used. The CW25-TIM has an internal blocking diode, so if a "supercap" or rechargeable battery is used, an external charging circuit will be required.

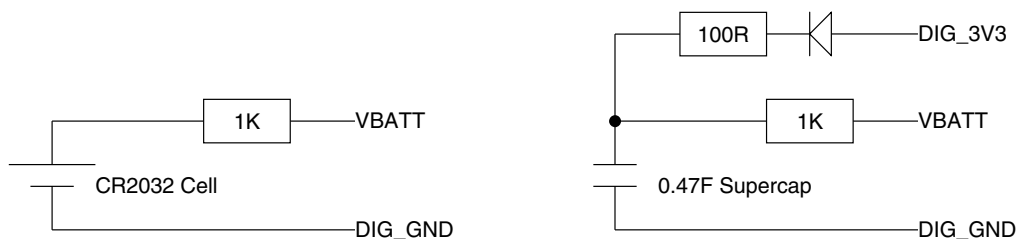

Figure 9 Typical VBATT Supplies

9 APPLICATION HINTS continued

9.5 Over Voltage & Reverse Polarity Protection

The CW25-NAV contains no over voltage or reverse polarity protection. The CW25-NAV should be handled as a CMOS component, with full antistatic handling precautions. Any fault condition that results in the maximum limits being exceeded may irreparably damage the CW25-NAV.

9.6 LEDs

There are two connections on the CW25-NAV specifically intended to drive status LEDs. The LED_RED and LED_GRN signals should be connected, via suitable current limiting resistors, to the anodes of low current LEDs whose cathodes are connected to DIG_GND. The outputs are standard 3.3V CMOS and the current drawn should be limited to 5mA per output. Using a 270 Ω resistor provides a suitable current limit. If appropriately colored LEDs are attached to these signals, other documentation (eg. user manuals) that refers to these status LEDs will be correct. If LEDs are not required, these signals can be left open. These signals may be connected to other logic if required.

9.7 Reset Generation

The power on reset for the CW25-NAV is generated on-board. It is generated by the regulator for the RF section. This signal is an active low, open collector signal and is presented on the NPOR castellation. If it is desired to extend the power on reset signal or provide a manual reset for the CW25-NAV, this signal can be driven from an open collector source at any time. The nPOR signal of the BB251C, to which the NPOR castellation is connected, has a Schmitt trigger input. This means that there are no constraints on the rise time of the NPOR signal.

There is a second reset signal on the CW25-NAV, the NRESET signal. NRESET is also an active low open collector signal. This signal is generated by the BB251C in response to the NPOR signal. It can also be generated under software control. Asserting the NRESET signal from an external open collector source will reset the ARM9 in the BB251C without resetting the whole chip. Generally, this signal will be left open.

9.8 Boot Options

The CW25-NAV has two boot modes. These are selected by the state of the BOOTSEL signal when the NPOR signal goes inactive (high). Normally, BOOTSEL is left open so that a pull-up bias in the BB251C will keep that signal high. When BOOTSEL is high, the CW25-NAV boots from the FLASH that is internal to the BB251C. If BOOTSEL is tied low, the CW25-NAV boots from the ROM internal to the BB251C. This ROM has a boot loader that polls the serial ports and I2C bus for boot code. This mode of operation requires special user handling and should only be used in conjunction with specific application notes.

9.9 Demo Board Kit Information

A CW25 demo board is available for evaluation of the CW25 receiver. A full kit contains the demo board with mounted CW25-TIM or CW25-NAV, RS232 serial cable, power supply adaptor (region specific) with a 2.1 mm DC plug and a 3m TNC magnetic match antenna.

To reduce costs, the CW25 demo board can be purchased separately with a pick-and-choose option for above accessories.

See CW25 Demo User Manual for more detailed information on this unit.

Please contact NavSync for pricing information on the full kit or individual items.

NAVSYNC

CW25-TIM

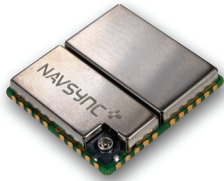

NavSync, Ltd. Europe

Bay 143

Shannon Industrial Estate

Shannon, Co. Clare, Ireland

Phone: +353 61 475 666

E-mail: sales@navsync.com

North America

2111 Comprehensive Drive
Aurora, IL 60505, USA

Phone: 630.236.3026

E-mail: northamerica@navsync.com

www.navsync.com